

斗式提升机用减速机 Bucket Elevator Drives



型号表示 主减速机型号/辅传减速电机型号¹⁾

Designation of Types Main gear unit type / Auxiliary gear motor type¹⁾

例 Example: TB3DH13-71-B-CW/TKF108-Y18.5-28.59

主减速机型号说明 Explanation of main gear unit type

型号说明	上例说明	Explanation of types	Explanation of the above example
系列类型: TB 直交轴系列	直交轴系列	Types: TB Bevel-helical	Bevel-helical
传动级数: 3 三级	三级传动	Number of stages: 3 3-stage	3-stage
输出轴结构形式: S 实心轴 H 空心轴 D 带胀紧盘空心轴	带胀紧盘 空心轴输出	Output shaft design: S Solid shaft H Hollow shaft D Hollow shaft for shrink disk	Hollow shaft for shrink disk output
安装方式: H 卧式带底脚	卧式带底脚安装	Mounting positions: H Horizontal	Horizontal
规格代号: 4~18	13机座号	Size: sizes 4~18	size 13
公称传动比: 公称传动比 _N (见选型参数表)	公称传动比 _N =71	Nominal ratio: Nominal ratio _N (see selection table)	Nominal ratio _N =71
装配布置形式: B、D (见 TBED20 页)	装配布置形式为 B	Design for assemble: B, D (see page TBED20)	Design B
输入轴旋转方向 (面向输入轴方向看): CW 顺时针 CCW 逆时针	输入轴为 顺时针方向	Direction of rotation of input shaft: (viewing on input shaft) CW Clockwise, CCW Counter clockwise.	Direction of rotation of input shaft is clockwise

辅传减速电机型号说明²⁾ Explanation of auxiliary gear motor type²⁾

型号说明	上例说明	Explanation of types	Explanation of the above example
减速电机类型: 螺旋锥齿轮减速电机	螺旋锥齿轮减速电机	Gear units type: Helical-bevel gear motor	Helical-bevel gear motor
结构形式: F 轴伸法兰式	轴伸法兰式	Structure: F Flange mounted solid output shaft	Flange-mounted solid shaft output
机座号: 38...168	108机座号	Size: 38...168	Size 108
电机: 电机功率	18.5kW普通电机	Motor: motor power	18.5kW Ordinary motor
传动比: 见 TBED07 页	传动比: 28.59	Ratio: see page TBED07	Ratio: 28.59

注: 1) 使用国产及国外逆止器、超越离合器时, 尺寸略有不同 (见 TBED12-19 页减速机外形尺寸), 请特别说明。

2) 主减速机规格确定后, 依据辅传驱动为空载和载荷不同工作情况, 辅传减速电机型号基本确定, 见 TBED07 页。

Note: 1) Please specially designate whether domestic or imported backstop and overrunning clutch are used, as the dimensions are slightly different (see page TBED12-19 gear units mounting dimensions for detail).

2) Auxiliary gear motor type is basically determined depend on the auxiliary drive working under maintenance or under load condition after main gear unit has been selected (see page TBED07).

斗式提升机用减速机 Bucket Elevator Drives

注意事项

务必遵循以下原则：

样本中的附图只属范例，并不要求严格一致。所有尺寸可能改进。

所注重量仅为平均值，不要求严格一致。

为防止发生事故，所有旋转部件应按安全规定加罩防护。

试车前，必须认真阅读操作说明。主减速机出厂时未加注润滑油。因此应按规定加注润滑油。

给出的加油量只作为参考值，实际油量应以油尺上的标记为准。

通常，辅传减速电机TKF98以下在出厂前已加注润滑油。

采用国产逆止器、超越离合器时，需给逆止器和联接法兰之内的超越离合器加注润滑脂（2号锂基润滑脂可满足要求），并定期更换。采用国外逆止器、超越离合器时，需向联接法兰内加注润滑油（采用与主减速机同样规格润滑油）以润滑超越离合器，油位以略低于连接法兰视孔即可。

有关外形尺寸图中的符号说明如下：



= 油尺



= 通气孔



= 加油孔



= 放油孔

Attention

Following items are absolutely to be observed:

Illustrations are examples only and are not strictly bonding. Dimensions are subject to change.

The weights are mean values and not strictly binding.

To prevent accidents, all rotating parts should be guarded according to local and national safety regulations.

Prior to commissioning, the operating instructions must be observed. The gear units are delivered ready for operation but without oil filling. So specified oil should be filled.

Oil quantities given are guide values only. The exact quantity of oil depends on the marks on the dipstick.

Normally, auxiliary gear motors are filled with lubricant at the factory before dispatch.

If domestic backstop and overrunning clutch are used, please lubricate them with grease (No. 2 lithium grease can meet requirement), and change periodically. If imported backstop and overrunning clutch are used, please fill lubrication into the connecting flange to lubricate the overrunning clutch, as the backstop is lubricated with splash oil.

Explanations of symbols used in the dimensioned drawings:



= Oil dipstick



= Breather



= Oil filler



= Oil-out drain

基础螺栓的性能等级为8.8级。

Foundation bolts of min. property class 8.8.



选型指南

1. 确定减速机规格

1.1 计算传动比

$$i_s = \frac{n_1}{n_2}$$

1.2 确定减速机的额定功率，应满足(原动机为电机，每小时启动次数≤5次)

$$P_N \geq P_2 \times f_1 \times f_3$$

1.3 校核最大转矩，如峰值工作转矩，启动转矩或制动转矩，应满足(单向载荷，每小时峰值负荷次数≤5次)

$$P_N \geq \frac{T_A \times n_1}{9550} \times 0.5$$

根据 i_N 和 P_N 在额定功率表中确定减速机规格。

1.4 检查实际传动比 i 是否满足要求，实际传动比 i 见 TBED122-页25

2. 确定润滑方式

减速机采用浸油飞溅润滑。
可按客户要求提供强制润滑。

3. 确定热功率 P_G

3.1 减速机不带辅助冷却装置，应满足

$$P_2 \leq P_G = P_{G1} \times f_6 \times f_7$$

3.2 减速机带冷却风扇装置时，应满足

$$P_2 \leq P_G = P_{G2} \times f_6 \times f_7$$

3.3 更高的热功率，可按要求提供外部油冷却器冷却。

Guidelines for the Selection

1. Determination of gear unit type and size

1.1 Find the transmission ratio

$$i_s = \frac{n_1}{n_2}$$

1.2 Determine nominal power rating of the gear unit(drivn by electric motor, and start less than five times per hour)

$$P_N \geq P_2 \times f_1 \times f_3$$

1.3 Check for maximum torque, e.g. peak operating-, starting- or braking torque (unilateral loading, and endure peak loads less than five times per hour)

$$P_N \geq \frac{T_A \times n_1}{9550} \times 0.5$$

Gear unit sizes are given in rating tables depending on i_N and P_N .

1.4 Check whether the actual ratio i as per tables on page 445~446 is acceptable.

2. Determination of oil supply

All parts to be lubricated are lying in the oil or are splash lubricated.Forced lubrication on request.

3. Determination of required thermal capacity P_G

3.1 Gear unit without auxiliary cooling sufficient, if

$$P_2 \leq P_G = P_{G1} \times f_6 \times f_7$$

3.2 Gear unit with fan sufficient, if

$$P_2 \leq P_G = P_{G2} \times f_6 \times f_7$$

3.3 For higher thermal capacities, cooling by external oil cooler on request.

斗式提升机用减速机 Bucket Elevator Drives

符号表

E_D = 每小时工作周期, 以%表示, 例如 $E_D=80\%$

f_1 = 工作机系数 (表1), 见 TBED06 页

f_3 = 减速机安全系数 (表3), 见 TBED06 页

f_6 = 环境温度系数 (表6), 见 TBED06 页

f_7 = 海拔高度系数 (表7), 见 TBED06 页

i = 实际传动比

i_N = 额定传动比

i_s = 要求传动比

n_1 = 输入转速 (r/min)

n_2 = 输出转速 (r/min)

n_3 = 辅传驱动(50Hz; $n_1=1500$ r/min)输入时的主减速机 (TB3) 输出轴上的输出转速(r/min)

P_G = 需要的热功率

P_{G1} = 无辅助冷却装置时的热功率, 见 TBED09-11 页

P_{G2} = 带冷却风扇装置时的热功率, 见 TBED09-11 页

P_N = 减速机的额定功率(kW), 见选型表 TBED38 页

P_2 = 工作机的额定功率 (kW)

t = 环境温度(°C)

T_A = 输入轴最大扭矩, 例如峰值工作扭矩, 起动扭矩或制动扭矩 (Nm)

T_{2N} = 额定输出扭矩 (kNm), 见 TBED38 页

T_3 = 辅传驱动输入时的主减速机 (TB3) 输出轴上的输出扭矩 (kNm), 见 TBED07 页

Key to Symbols

E_D = Operation cycle per hour in %, e.g. $E_D=80\%$

f_1 = Factor for driven machine (table 1), page TBED06

f_3 = Safety factor (table 3), page

f_6 = factor for ambient temperature (table 6), page

f_7 = Factor for altitude (table 7), page TBED06

i = Actual ratio

i_N = Nominal ratio

i_s = Required ratio

n_1 = Input speed (r/min)

n_2 = Output speed (r/min)

n_3 = Output speed (r/min) on main gear unit output shaft (TB3), in case of input via auxiliary drive (50Hz; $n_1=1500$ r/min)

P_G = Required thermal capacity

P_{G1} = Thermal capacity for gear units without auxiliary cooling, page TBED09-11

P_{G2} = Thermal capacity for gear units with fan cooling, page TBED09-11

P_N = Nominal power rating of gear unit (kW), see rating table at page TBED38

P_2 = Power rating of driven machine (kW)

t = Ambient temperature (°C)

T_A = Max. torque occurring on input shaft, e.g. peak operating-, starting- or braking torque (Nm)

T_{2N} = Nominal output torque (kNm), page TBED38

T_3 = Output torque (kNm) on main gear unit output shaft (TB3), in case of input via auxiliary drive, page TBED07

斗式提升机用减速机 Bucket Elevator Drives



计算实例

已知条件:

原动机

电动机: $P_1=75\text{kW}$

电机转速: $n_1=1500\text{ r/min}$

最大起动扭矩: $T_A=720\text{Nm}$

工作机

斗式输送机: $P_2=62\text{kW}$

转速: $n_2=26\text{ r/min}$

日工作小时数: 12小时/天

每小时起动次数: 7

辅传驱动: 载荷驱动

每小时工作周期: $E_D=100\%$

环境温度: 30°C

室外安装: 风速 $\geq 4\text{m/s}$

海拔高度: 海平面

减速机类型

直交轴减速机

安装方式: 水平安装

输出轴: 右面

输出轴的旋转方向: CCW

要求:

选择减速机类型和规格

1.选择减速机类型和规格

1.1确定传动比

$$i_s = \frac{n_1}{n_2} = \frac{1500}{26} = 57.7 \quad i_N = 56$$

1.2确定减速机额定功率

$$P_N \geq P_2 \times f_1 \times f_3 = 62 \times 1.5 \times 1.25 = 116.25\text{kW}$$

从功率表中选择: 类型TB3, 规格10, 额定功率 $P_N=122\text{kW}$

带载辅传驱动TKF88-Y5.5-36.52,

$n_3=2.0\text{ r/min}$ 及 $T_3=25.1\text{kNm}$ 。

1.3校核起动扭矩

$$P_N \geq \frac{T_A \times n_1}{9550} \times 0.5 = \frac{720 \times 1500}{9550} \times 0.5 = 56.6\text{kW}$$

$$P_N = 122\text{kW} > 56.6\text{kW}$$

2.确定热功率

2.1按TB3不带冷却装置时热功率计算:

$$P_G = P_{G1} \times f_6 \times f_7 = 72 \times 0.88 \times 1.0 = 63.36\text{kW}$$

$$P_2 = 62\text{kW} < P_G = 63.36\text{kW}$$

可选用不带冷却装置的减速机。

Calculation Example

Known criteria:

PRIME MOVER

Electric motor: $P_1=75\text{kW}$

Motor speed: $n_1=1500\text{ r/min}$

Max. starting torque: $T_A=720\text{Nm}$

DRIVEN MACHINE

Bucket conveyors: $P_2=62\text{kW}$

Speed: $n_2=26\text{ r/min}$

Daily service hours: 12h / day

Starts per hour: 7

Auxiliary drive: operation under load

Operating cycle per hour: $E_D=100\%$

Ambient temperature: 30°C

Outdoor installation: wind velocity $\geq 4\text{m/s}$

Altitude: sea level

GEAR UNIT DESIGN

Bevel-helical gear unit

Mounting position: horizontal

Output shaft: right hand side

Rotate direction of of output shaft: CCW

Required

Type and size of gear unit

1.Selection of gear unit type and size

1.1Calculation of transmission ratio

$$i_s = \frac{n_1}{n_2} = \frac{1500}{26} = 57.7 \quad i_N = 56$$

1.2Determination of the gear unit nominal power rating

$$P_N \geq P_2 \times f_1 \times f_3 = 62 \times 1.5 \times 1.25 = 116.25\text{kW}$$

Selected from power rating table: type TB3, gear unit size 10, with $P_N=122\text{kW}$

With auxiliary drive TKF88-Y5.5-36.52,

$n_3=2.0\text{ r/min}$ and $T_3=25.1\text{kNm}$ 。

1.3Checking the starting torque

$$P_N \geq \frac{T_A \times n_1}{9550} \times 0.5 = \frac{720 \times 1500}{9550} \times 0.5 = 56.6\text{kW}$$

$$P_N = 122\text{kW} > 56.6\text{kW}$$

2.Determination of thermal capacity

2.1Thermal capacity for gear units without auxiliary cooling, acc. to table for type TB3

$$P_G = P_{G1} \times f_6 \times f_7 = 72 \times 0.88 \times 1.0 = 63.36\text{kW}$$

$$P_2 = 62\text{kW} < P_G = 63.36\text{kW}$$

A GEAR UNIT WITHOUT AUXILIARY COOLING IS SUFFICIENT!

斗式提升机用减速机 Bucket Elevator Drives

服务系数 Service Factors

表1 工作机系数 f_1
Table 1 Factor for driven machine f_1

工作机 Driven machines	日工作小时数 Effective daily operating period under load in hours			工作机 Driven machines	日工作小时数 Effective daily operating period under load in hours		
	≤0.5	0.5~10	>10		≤0.5	0.5~10	>10
输送机** Conveyors **				货用电梯* Goods lifts *	-	1.2	1.5
斗式输送机 Bucket conveyors	-	1.4	1.5	客用电梯* Passenger lifts *	-	1.5	1.8
升降卷扬机 Hauling winches	1.4	1.6	1.6	刮板式输送机 Apron conveyors	-	1.2	1.5
提升机 Hoists	-	1.5	1.8	自动扶梯 Escalators	1.0	1.2	1.4
带式输送机 ≤150kW Belt conveyors ≤150kW	1.0	1.2	1.3	轨道车辆 Railway Vehicles	-	1.5	-
带式输送机 >150kW Belt conveyors >150kW	1.1	1.3	1.4				

注：*) 按最大扭矩确定额定功率；
**) 检验热功率是绝对有必要的。

Note:*) Designed power corresponding to max. torque;
**) A check for thermal capacity is absolutely essential.

表3 减速器安全系数 f_3 Table 3 Safety factor f_3

重要性与安全要求	一般设备，减速器失效仅引起单机停产且易更换备件	重要设备，减速器失效引起起机组、生产线或全厂停产	高度安全要求，减速器失效引起设备、人身事故
Importance and safety request	Ordinary equipment, malfunction only cause accident of single machine and easily replaced.	Important equipment, malfunction cause the accident of assembling unit, production-line or whole factory.	Safety request highly, malfunction cause the accident of equipment and personal injury.
f_3	1.25-1.5	1.5-1.75	1.75-2.0

表6 环境温度系数 f_6 Table 6 Thermal factor f_6

环境温度 Ambient temperature	不带辅助冷却装置或仅带冷却风扇 Without auxiliary cooling or with fan cooling				
	每小时工作周期 (ED) 百分比 % Operating cycle per hour (ED) in %				
	100	80	60	40	20
10°C	1.11	1.31	1.60	2.14	3.64
20°C	1.00	1.18	1.44	1.93	3.28
30°C	0.88	1.04	1.27	1.70	2.89
40°C	0.75	0.89	1.08	1.45	2.46
50°C	0.63	0.74	0.91	1.22	2.07

表7 海拔高度系数 f_7 Table 7 Factor for altitude f_7

系数 Factor	不带辅助冷却装置或仅带冷却风扇 Without auxiliary cooling or with fan cooling				
	海拔高度 (m) Altitude (meters)				
	高达 Up to 1000	高达 Up to 2000	高达 Up to 3000	高达 Up to 4000	高达 Up to 5000
f_7	1.0	0.95	0.90	0.85	0.80

斗式提升机用减速机 Bucket Elevator Drives

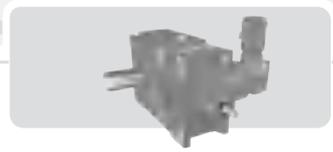

辅传驱动

类型TB3...

规格4...18

依据不同的使用要求，每种规格的减速机有两种辅传驱动型式：

1) 空载驱动

斗式提升机空载(空斗)时，辅传减速机驱动斗式提升机以较低转速同向转动。

2) 载荷驱动

斗式提升机满载(满斗)时，辅传减速机驱动斗式提升机以较低转速同向转动。

辅传驱动结构设计

辅传减速机为TKF系列带直联电机的锥齿轮减速电机，通过中间法兰与主减速机相联接，超越离合器与主减速机相连实现自动离合。超越离合器在中间法兰内部，有独立油润滑和加润滑油脂润滑两种方式。TKF锥齿轮减速电机也为独立油润滑方式，出厂前已加注润滑油。

Auxiliary Drive

Types TB3...

Sizes 4...18

Dependent on the case of application, for each gear unit size two different auxiliary drives are available:

1) Maintenance Drive

The motor of the auxiliary drive is dimensioned in such a way that the bucket elevator can be operated with empty buckets at low speed in the same direction of rotation.

2) Operation under load

The motor of the auxiliary drive is dimensioned in such a way that the bucket elevator can be operated with full buckets at low speed in the same direction of rotation.

Design of auxiliary drives

The auxiliary drive is a bevel-helical gear motor type TKF, which is flanged to the main gear unit by means of an intermediate flange and is coupled to the main gear units via an overrunning clutch. The overrunning clutch is located in the intermediate flange, and lubricated with its own oil or grease. The bevel-helical gear motor type TKF has an own oil filling and is supplied filled with oil.

主减速机 Main gear Unit	空载驱动 Maintenance drive						载荷驱动 Operation under load					
	1) n_3 [r/min]	1) T_3 [kNm]	2) 齿轮减速电机 Geared motor	P_M [kW]	输出轴 $d \times l$ [mm]	i	1) n_3 [r/min]	1) T_3 [kNm]	2) 齿轮减速电机 Geared motor	P_M [kW]	输出轴 $d \times l$ [mm]	i
4	2.5	2.7	TKF48-Y0.75-35.39	0.75	30 × 60	35.39	2.5	3.9	TKF58-Y1.1-35.7	1.1	35 × 70	35.7
5	2.5	5.3	TKF58-Y1.5-35.7	1.5	35 × 70	35.7	3.3	6.5	TKF68-Y2.2-27.28	2.2	40 × 80	27.28
6	2.0	6.6	TKF58-Y1.5-35.7	1.5	35 × 70	35.7	2.7	8.1	TKF68-Y2.2-27.28	2.2	40 × 80	27.28
7	3.0	6.6	TKF68-Y2.2-30.21	2.2	40 × 80	30.22	3.1	11.5	TKF78-Y4-29.26	4	50 × 100	29.27
8	2.4	8.3	TKF68-Y2.2-30.21	2.2	40 × 80	30.22	2.5	14.5	TKF78-Y4-29.26	4	50 × 100	29.27
9	2.9	9.4	TKF78-Y3-30.88	3.0	50 × 100	30.89	2.5	20.0	TKF88-Y5.5-36.52	5.5	60 × 120	36.52
10	2.3	11.7	TKF78-Y3-30.88	3.0	50 × 100	30.89	2.0	25.1	TKF88-Y5.5-36.52	5.5	60 × 120	36.52
11	2.3	11.8	TKF78-Y3-40.04	3.0	50 × 100	40.04	2.7	36.0	TKF98-Y11-34.22	11	70 × 140	34.23
12	1.8	15.0	TKF78-Y3-40.04	3.0	50 × 100	40.04	2.2	45.8	TKF98-Y11-34.22	11	70 × 140	34.23
13	2.1	17.3	TKF88-Y4-44.02	4.0	60 × 120	44.02	3.3	51.0	TKF108-Y18.5-28.59	18.5	90 × 170	28.59
14	1.7	21.7	TKF88-Y4-44.02	4.0	60 × 120	44.02	2.6	63.9	TKF108-Y18.5-28.59	18.5	90 × 170	28.59
15	2.1	16.9	TKF88-Y4-44.02	4.0	60 × 120	44.02	3.5	78.0	TKF128-Y30-27.67	30	110 × 210	27.67
16	1.9	19.2	TKF88-Y4-44.02	4.0	60 × 120	44.02	3.0	88.5	TKF128-Y30-27.67	30	110 × 210	27.67
17	2.1	17.2	TKF88-Y4-44.02	4.0	60 × 120	44.02	3.4	97.5	TKF128-Y37-27.67	37	110 × 210	27.67
18	1.8	20.0	TKF88-Y4-44.02	4.0	60 × 120	44.02	2.9	113.2	TKF128-Y37-27.67	37	110 × 210	27.67
减速机布置形式 Design of gear units												
主减速机TB布置形式: D Design of main gear unit TB: D 齿轮减速电机TKF输出轴方向: A Output shaft direction of gear motor TKF: A						主减速机TB布置形式: B Design of main gear unit TB: B 齿轮减速电机TKF输出轴方向: B Output shaft direction of gear motor TKF: B						

注: 1) 辅传驱动输入时主减速机输出轴上转速、转矩 (50Hz, $n_1 = 1500$ r/min) ;

2) 齿轮减速电机TKF规格。

Note: 1) Output speed and torque on main gear unit output shaft in case of input via auxiliary drive (50Hz, $n_1 = 1500$ r/min);

2) Gear motor TKF size.

斗式提升机用减速机 Bucket Elevator Drives

直交轴减速器

Bevel-helical gear units

额定功率

Nom. power ratings

类型 TB3...

Type TB3...

规格 4...18

Sizes 4...18

		额定功率 P _N								Nominal power ratings P _N										
i _N	n ₁ r/min	n ₂ r/min	规 格								S izes								kW	
			4	5	6	7	8	9	10	11	12	13	14	15	16	17	18			
25	1500	60	41	69	91	129	160	214	270	377	471	553	685	961	1087	1257	1508			
	1000	40	28	46	61	86	107	142	180	251	314	369	457	641	725	838	1005			
	750	30	21	35	46	64	80	107	135	188	236	276	342	481	543	628	754			
28	1500	54	37	62	82	116	144	192	243	339	424	498	616	865	978	1131	1357			
	1000	36	25	41	55	77	96	128	162	226	283	332	411	577	652	754	905			
	750	27	19	31	41	58	72	96	122	170	212	249	308	433	489	565	679			
31.5	1500	48	33	55	73	103	128	171	216	302	377	442	548	769	870	1005	1206			
	1000	32	22	37	49	69	85	114	144	201	251	295	365	513	580	670	804			
	750	24	17	28	36	52	64	85	108	151	188	221	274	385	435	503	603			
35.5	1500	42	29	48	64	90	112	150	189	264	330	387	479	673	761	880	1055			
	1000	28	19	32	43	60	75	100	126	176	220	258	320	449	507	586	704			
	750	21	15	24	32	45	56	75	95	132	165	194	240	336	380	440	528			
40	1500	38	26	44	58	82	101	135	171	239	298	350	434	609	688	796	955			
	1000	25	17	29	38	54	67	89	113	157	196	230	285	401	453	524	628			
	750	18.8	13	22	29	40	50	67	85	113	148	173	215	301	341	394	472			
45	1500	33	23	38	50	71	88	117	149	207	259	304	377	529	598	691	829			
	1000	22	15	25	33	47	59	78	99	138	173	203	251	352	399	461	553			
	750	16.7	12	19	25	36	45	59	75	105	131	154	191	268	303	350	420			
50	1500	30	21	35	46	64	80	107	135	188	236	276	342	481	543	628	754			
	1000	20	14	23	30	43	53	71	90	126	157	184	228	320	362	419	503			
	750	15	10.4	17	23	32	40	53	68	94	118	138	171	240	272	314	377			
56	1500	27	19	31	41	58	72	96	122	170	212	249	308	433	489	565	679			
	1000	17.9	12	21	27	38	48	64	81	112	141	165	204	287	324	375	450			
	750	13.4	9.3	15	20	29	36	48	60	84	105	123	153	215	243	281	337			
63	1500	24	17	28	36	50	64	85	108	151	188	221	274	385	435	503	603			
	1000	15.9	11	18	24	33	42	57	72	100	125	147	181	255	288	333	400			
	750	11.9	8.2	14	18	25	32	42	54	75	93	110	136	191	216	249	299			
71	1500	21	14.5	24	32	44	56	75	95	132	165	194	240	336	380	440	528			
	1000	14.1	9.7	16	21	30	38	50	63	89	111	130	161	226	255	295	354			
	750	10.6	7.3	12	16	22	28	38	48	67	83	98	121	170	192	222	266			

TB
ED
08



卧式安装减速器要求强制润滑



Forced lubrication required on horizontal gear units

斗式提升机用减速机 Bucket Elevator Drives

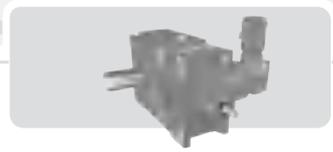

直交轴减速器

Bevel-helical gear units

热功率

Thermal capacities

类型 TB3...

Type TB3...

规格 4...18

Sizes 4...18

$n_1=1500$ r/min

$n_1=1500$ r/min

		热功率 P_G								Thermal capacities P_G								kW	
i_N		热功率取决于冷却方式: P_{G1} :无辅助冷却装置; P_{G2} :带冷却风扇 Thermal capacity dependent on kind of cooling: P_{G1} :without auxiliary cooling; P_{G2} :fan cooling																	
		规 格								S izes									
		4	5	6	7	8	9	10	11	12	13	14	15	16	17	18			
25	P_{G1}	31.9	43.3	50.1	66.2	75.2	86.9	92.8	109	130	128	150	153	160					
	P_{G2}	66.7	96.6	110	151	170	209	223	307	375	395	466	537	585	681	732			
28	P_{G1}	30.9	42.5	50	64.1	74.4	85	93.1	109	131	131	155	168	172	183	182			
	P_{G2}	63.9	93.3	109	143	165	199	220	296	363	380	452	535	562	689	711			
31.5	P_{G1}	29.4	40.7	47.8	61.7	72.7	82.7	90.7	106	129	131	154	170	183	190	199			
	P_{G2}	60.7	88.5	103	136	160	190	210	282	344	365	430	508	558	658	712			
35.5	P_{G1}	27.8	38.6	46.4	59.1	69.8	79.6	87.7	105	125	130	151	173	181	196	203			
	P_{G2}	56.8	83	99.8	129	152	181	199	271	328	353	412	495	526	644	677			
40	P_{G1}	24.3	33.7	44.3	52	67.1	75	84.4	100	121	125	147	168	180	194	204			
	P_{G2}	49.4	71.6	94.6	112	144	168	191	255	310	334	392	469	510	614	657			
45	P_{G1}	23.8	32.9	41.8	50.8	64	69.4	80.8	93.2	118	117	144	160	176	187	203			
	P_{G2}	48.3	69.8	88.5	108	137	154	180	234	298	306	377	434	484	572	629			
50	P_{G1}	24.2	33	36.8	50.7	56.9	69.3	77	95.8	115	124	142	174	174	210	204			
	P_{G2}	48.7	69.2	76.9	106	119	151	169	232	281	310	358	445	453	593	594			
56	P_{G1}	22.4	30.7	36.2	47.5	55.7	64.8	72	88.9	108	117	135	167	186	203	225			
	P_{G2}	44.8	64	75.1	99.5	116	140	155	211	260	285	330	411	461	552	612			
63	P_{G1}	21.6	29.5	36	46.1	55.2	62.8	71	86.3	108	114	138	162	173	199	211			
	P_{G2}	43.2	61.6	74.2	96.2	114	135	151	203	255	275	332	393	422	529	563			
71	P_{G1}	20	28.2	33.3	43.9	51.4	59	65.9	80.2	99.9	107	127	155	167	190	205			
	P_{G2}	40	58.5	68.4	91.7	106	126	140	189	232	258	302	372	404	498	539			

注: 表中数值按:
每小时工作周期: 100%
在室内大空间安装*
海拔高度至1000m

Note: Values refer to:
Operating cycle: 100%
Installation in a large hall*
Altitude up to 1000m

*)室内小空间(风速 < 1.4 m/s)和室外(风速 ≥ 4 m/s), 请垂询。

*)Calculation consult us when small confined space(wind velocity < 1.4 m/s) or in the open (wind velocity ≥ 4 m/s)

斗式提升机用减速机 Bucket Elevator Drives

直交轴减速器

Bevel-helical gear units

热功率

Thermal capacities

类型 TB3...

Type TB3...

规格 4...18

Sizes 4...18

$n_1=1000$ r/min

$n_1=1000$ r/min

i_N	热功率 P_G								Thermal capacities P_G								kW	
	热功率取决于冷却方式: P_{G1} :无辅助冷却装置; P_{G2} :带冷却风扇 Thermal capacity dependent on kind of cooling: P_{G1} :without auxiliary cooling; P_{G2} :fan cooling																	
	规 格								S izes									
	4	5	6	7	8	9	10	11	12	13	14	15	16	17	18			
25	P_{G1}	30.1	41.8	48.6	65	74.7	87.3	94.3	117	144	149	176	204	222	234	250		
	P_{G2}	51.7	75.5	86.9	119	134	166	178	250	309	329	390	466	513	607	661		
28	P_{G1}	29	40.6	48	62.1	72.7	83.9	92.7	113	140	144	172	205	216	239	248		
	P_{G2}	49.4	72.7	85.5	112	130	157	174	238	295	312	373	453	480	596	621		
31.5	P_{G1}	27.5	38.6	45.5	59.2	70.3	80.6	89.1	108	133	139	165	196	215	232	250		
	P_{G2}	46.8	68.7	80.6	106	125	149	165	225	276	296	350	423	468	557	608		
35.5	P_{G1}	25.9	36.4	44	56.4	67	76.9	85.3	105	128	135	159	192	205	228	241		
	P_{G2}	43.8	64.3	77.5	100	119	141	156	215	262	284	332	407	435	538	569		
40	P_{G1}	22.6	31.7	41.8	49.4	64.1	72.1	81.6	99.6	122	128	152	183	199	220	236		
	P_{G2}	38.1	55.5	73.3	87.1	112	131	149	201	246	267	315	383	419	508	548		
45	P_{G1}	22.1	30.9	39.3	48	60.9	66.4	77.7	91.6	117	119	147	171	190	206	228		
	P_{G2}	37.2	54	68.5	84.1	106	120	140	184	236	244	301	352	395	470	520		
50	P_{G1}	22.4	30.8	34.4	47.6	53.6	65.5	73.1	92.4	112	122	141	178	179	219	216		
	P_{G2}	37.4	53.3	59.4	82.5	92.5	117	131	181	221	244	283	356	363	478	481		
56	P_{G1}	20.7	28.5	33.6	44.3	52.1	60.7	67.7	84.5	103	113	131	165	186	205	228		
	P_{G2}	34.4	49.3	57.8	76.7	89.6	108	120	164	203	223	258	325	365	438	488		
63	P_{G1}	19.9	27.4	33.4	42.8	51.5	58.7	66.5	81.7	103	109	133	159	171	198	211		
	P_{G2}	33.1	47.3	57.1	74.1	88.1	104	117	158	198	214	259	309	333	419	447		
71	P_{G1}	18.4	26.1	30.8	40.8	47.8	55	61.7	75.7	94.8	103	122	151	164	187	204		
	P_{G2}	30.7	44.9	52.6	70.5	81.7	97.8	108	146	180	201	236	292	318	393	426		

注: 表中数值按:
每小时工作周期: 100%
在室内大空间安装*
海拔高度至1000m

Note: Values refer to:
Operating cycle: 100%
Installation in a large hall*
Altitude up to 1000m

*)室内小空间(风速 < 1.4 m/s)和室外(风速 ≥ 4 m/s), 请垂询。

*)Calculation consult us when small confined space(wind velocity < 1.4 m/s) or in the open (wind velocity ≥ 4 m/s)

斗式提升机用减速机 Bucket Elevator Drives

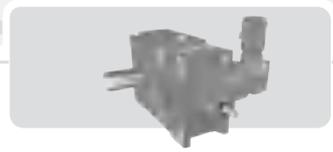

直交轴减速器

Bevel-helical gear units

热功率

Thermal capacities

类型 TB3...

Type TB3...

规格 4...18

Sizes 4...18

$n_1=750$ r/min

$n_1=750$ r/min

i_N	热功率 P_G							Thermal capacities P_G							kW	
	热功率取决于冷却方式: P_{G1} :无辅助冷却装置; P_{G2} :带冷却风扇 Thermal capacity dependent on kind of cooling: P_{G1} :without auxiliary cooling; P_{G2} :fan cooling															
	规格							Sizes								
	4	5	6	7	8	9	10	11	12	13	14	15	16	17	18	
25	P_{G1}	28.1	39.4	45.9	61.7	71.2	83.7	90.9	115	144	151	179	216	237	254	276
	P_{G2}	43.6	63.9	73.5	100	114	141	151	213	264	282	335	402	443	526	574
28	P_{G1}	27	38.1	45.1	58.6	68.8	79.8	88.5	109	137	144	172	211	224	252	264
	P_{G2}	41.7	61.4	72.2	94.8	110	133	147	202	251	266	318	389	412	513	536
31.5	P_{G1}	25.5	36.1	42.6	55.6	66.3	76.3	84.6	104	129	136	163	198	219	238	260
	P_{G2}	39.5	58	68.1	89.8	106	126	140	191	235	252	298	362	401	479	523
35.5	P_{G1}	24	34	41.1	52.8	63	72.5	80.6	100	123	132	155	191	205	231	247
	P_{G2}	36.9	54.3	65.4	84.8	100	120	132	182	222	241	283	348	372	460	488
40	P_{G1}	21	29.5	39	46.2	60.1	67.8	76.9	94.9	117	124	148	181	198	221	239
	P_{G2}	32.1	46.8	61.9	73.6	95.4	111	126	170	209	227	267	327	358	434	469
45	P_{G1}	20.5	28.7	36.6	44.9	57	62.3	73	87	112	114	141	168	187	205	228
	P_{G2}	31.3	45.6	57.8	71	90	101	119	156	200	207	256	300	336	401	444
50	P_{G1}	20.7	28.6	31.9	44.2	49.9	61.2	68.3	87	106	116	134	172	173	213	211
	P_{G2}	31.5	45	50.1	69.6	78.1	98.8	111	153	187	207	240	302	309	407	409
56	P_{G1}	19.1	26.3	31.1	41	48.4	56.5	63	79.1	97.4	107	123	157	177	197	220
	P_{G2}	28.9	41.5	48.7	64.7	75.6	91.4	101	139	171	189	218	275	310	372	414
63	P_{G1}	18.3	25.3	30.9	39.7	47.8	54.5	61.8	76.3	96.6	103	125	150	162	189	202
	P_{G2}	27.9	39.9	48.1	62.4	74.3	88.2	98.8	133	168	181	219	262	282	355	379
71	P_{G1}	17	24.1	28.5	37.8	44.3	51	57.3	70.6	88.6	96	115	143	155	178	194
	P_{G2}	25.9	37.9	44.3	59.5	68.9	82.5	91.7	123	152	169	199	247	269	333	361

注: 表中数值按:
每小时工作周期: 100%
在室内大空间安装*
海拔高度至1000m

Note: Values refer to:
Operating cycle: 100%
Installation in a large hall*
Altitude up to 1000m

*)室内小空间 (风速 < 1.4 m/s) 和室外 (风速 ≥ 4 m/s), 请垂询。

*)Calculation consult us when small confined space(wind velocity < 1.4 m/s) or in the open (wind velocity ≥ 4 m/s)

斗式提升机用减速机 Bucket Elevator Drives

直交轴减速机 Bevel-helical Gear Units
带辅传 With Auxiliary Drive
空载驱动 Maintenance Drive

三级 Three Stage
类型 Type TB3...
规格 Sizes 4 ... 12

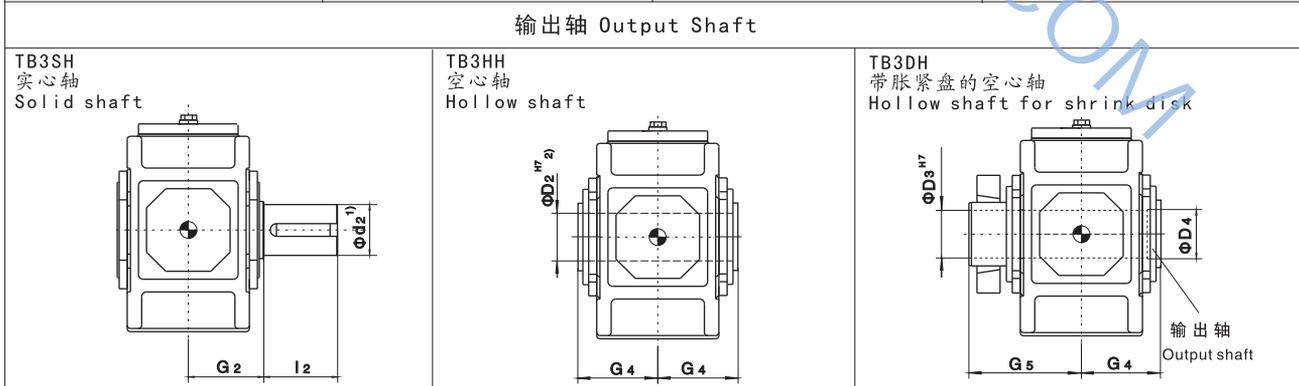
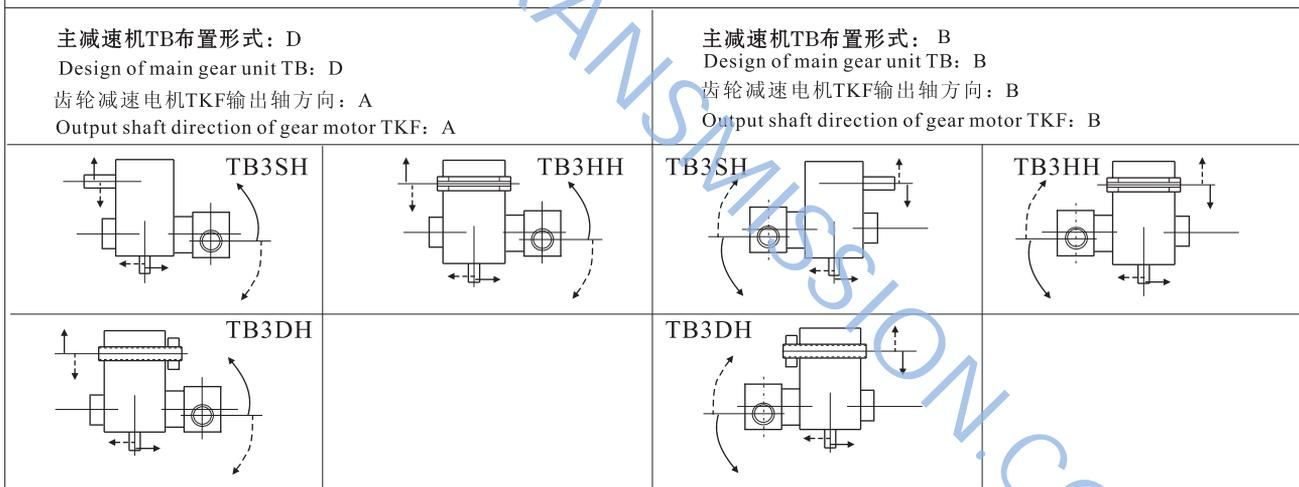
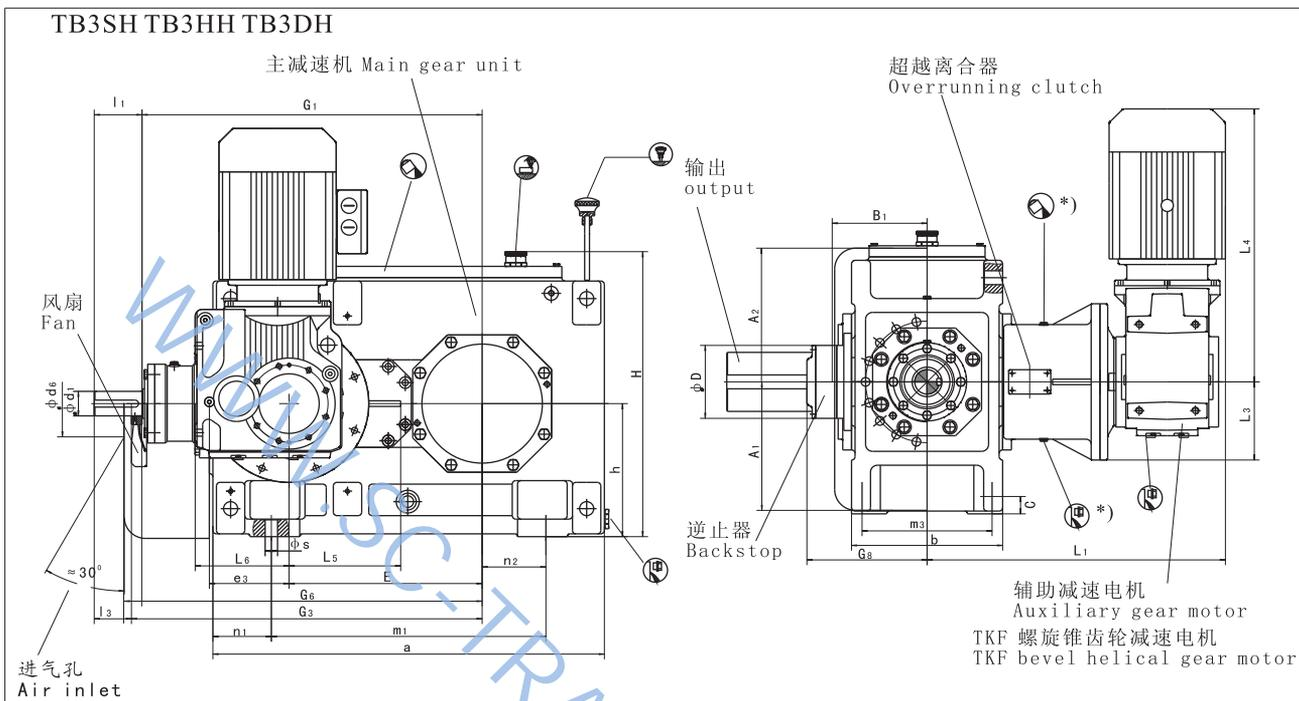

1) $k6 \leq \Phi 25$ $\Phi 28 \leq m6 \leq \Phi 100$ $n6 > \Phi 100$ 1) $k6 \leq \Phi 25$ $\Phi 28 \leq m6 \leq \Phi 100$ $n6 > \Phi 100$
 有关键和中心孔, 参见第 2 页 For parallel key and for center hole, see page 2
 2) 键槽GB/T1095-1979 2) Keyway GB/T1095-1979
 *) 仅当采用国外超越离合器时加注润滑油, 若采用国产逆止器、超越离合器时则加注润滑脂。
 *) Fill lubrication only when selecting imported overrunning clutch, if domestic backstop and overrunning clutch are used please fill grease.

斗式提升机用减速机 Bucket Elevator Drives

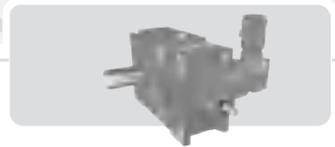

直交轴减速机 Bevel-helical Gear Units
带辅传 With Auxiliary Drive
空载驱动 Maintenance Drive

三级 Three Stage
类型 Type TB3...
规格 Sizes 4...12

规格 Size	辅传减速机 Auxiliary gear motor	尺寸 mm 输入轴 Dimensions in mm Input shaft												G ₁	G ₃
		i _N =25-45			i _N =25-56			i _N =50-71			i _N =63-71				
		d ₁ ¹⁾	l ₁	l ₃	d ₁ ¹⁾	l ₁	l ₃	d ₁ ¹⁾	l ₁	l ₃	d ₁ ¹⁾	l ₁	l ₃		
4	TKF48-Y0.75-35.39	30	70	50				25	60	40				500	520
5	TKF58-Y1.5-35.7	35	80	60				28	60	40				575	595
6	TKF58-Y1.5-35.7				35	80	60				28	60	40	610	630
7	TKF68-Y2.2-30.22	45	100	80				35	80	60				690	710
8	TKF68-Y2.2-30.22				45	100	80				35	80	60	735	755
9	TKF78-Y3-30.89	55	110	80				40	100	70				800	830
10	TKF78-Y3-30.89				55	110	80				40	100	70	850	880
11	TKF78-Y3-40.04	70	135	105				50	110	80				960	990
12	TKF78-Y3-40.04				70	135	105				50	110	80	1030	1060

规格 Size	尺寸 mm 减速机 Gear units Dimensions in mm Gear units													
	a	A ₁	a ₂	b	B ₁	c	d ₆	e ₃	E	G ₆	G ₈ ⁵⁾		h	H
4	565	195	200	215	143	28	110	110	270	530	193	188*	200	445
5	640	220	235	255	168	28	130	130	315	605	218	213*	230	512
6	720	220	235	255	168	28	130	130	350	640	218	213*	230	512
7	785	275	275	300	193	35	165	160	385	720	273	266*	280	602
8	890	275	275	300	193	35	165	160	430	765	273	266*	280	617
9	925	315	325	370	231	40	175	185	450	845	347	327*	320	697
10	1025	315	325	380	231	40	175	185	500	895	347	327*	320	697
11	1105	370	385	430	263	50	190	225	545	1010	397	342*	380	817
12	1260	370	385	430	263	50	190	225	615	1080	397	342*	380	825

规格 Size	尺寸 mm 减速机 Gear units Dimensions in mm Gear units												
	m ₁	m ₃	n ₁	n ₂	s	L ₁ ³⁾		L ₃	L ₄	L ₅	L ₆	D ⁵⁾	
4	355	180	105	85	19	447	447*	103	459	137	112	132	132*
5	430	220	105	100	19	512	507*	125	502	165	132	160	150*
6	510	220	105	145	19	512	507*	125	502	165	132	160	150*
7	545	260	120	130	24	555	555*	150	536	210	140	195	190*
8	650	260	120	190	24	555	555*	150	536	210	140	195	190*
9	635	320	145	155	28	655	650*	160	556	255	180	230	210*
10	735	320	145	205	28	655	650*	160	556	255	180	230	210*
11	775	370	165	180	35	702	692*	180	556	315	180	280	210*
12	930	370	165	265	35	702	692*	180	556	315	180	280	210*

规格 Size	尺寸 mm 输出轴 Output shaft Dimensions in mm Output shaft									润滑油 lubrication		重量 weight	
	TB3SH			TB3HH		TB3DH				TKF	TB3	TKF ³⁾	TB3/TKF ⁴⁾
	d ₂ ¹⁾	G ₂	l ₂	D ₂	G ₄	D ₃	D ₄	G ₄	G ₅	(L)	(L)	(kg)	(kg)
4	80	140	170	80	140	85	85	140	205	2.5	10	37	262
5	100	165	210	95	165	100	100	165	240	3.5	16	58	402
6	110	165	210	105	165	110	110	165	240	3.5	17	58	457
7	120	195	210	115	195	120	120	195	280	4	30	68	649
8	130	195	250	125	195	130	130	195	285	4	33	68	734
9	140	235	250	135	235	140	145	235	330	6.6	45	97	1017
10	160	235	300	150	235	150	155	235	350	6.6	48	97	1147
11	170	270	300	165	270	165	170	270	400	6.6	79	97	1582
12	180	270	300	180	270	180	185	270	405	6.6	84	97	1857

- 3) TKF减速机重量 (不含润滑油重量), 其余相关数据详见 TK03 页;
4) 主减速机与辅传减速机组合总重量 (不含润滑油重量);
5) 不带*列为采用国产逆止器、超越离合器时尺寸, 带*列为选用国外逆止器、超越离合器时尺寸。

- 3) Weight of gear motor TKF (oil weight not included), other detailed data refer to Page TK03 ;
4) Gross weight of combination of main gear unit and auxiliary gear motor (oil weight not included).
5) Without * is the dimension using domestic backstop and overrunning clutch and with * is the dimension using imported backstop and overrunning clutch.

斗式提升机用减速机 Bucket Elevator Drives

直交轴减速机 Bevel-helical Gear Units
带辅传 With Auxiliary Drive
空载驱动 Maintenance Drive

三级 Three Stage
类型 Type TB3...
规格 Sizes 13 ... 18

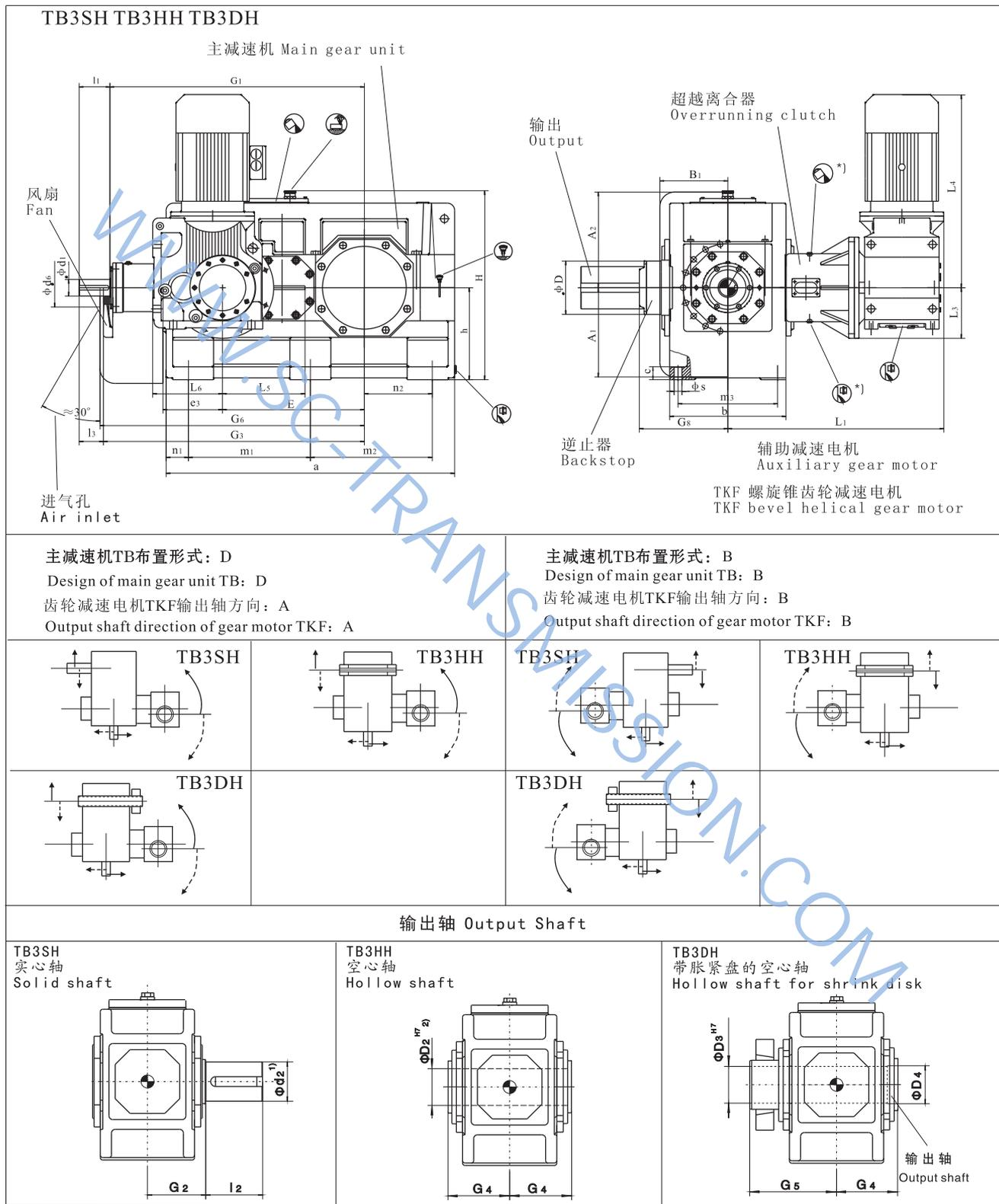

1) $k6 \leq \Phi 25$ $\Phi 28 \leq m6 \leq \Phi 100$ $n6 > \Phi 100$

有关平键和中心孔, 参见第 2 页

2) 键槽GB/T1095-1979

*) 仅当采用国外超越离合器时加注润滑油, 若采用国产逆止器、超越离合器时则加注润滑脂。

*) Fill lubrication only when selecting imported overrunning clutch, if domestic backstop and overrunning clutch are used please fill grease.

斗式提升机用减速机 Bucket Elevator Drives



直交轴减速机 Bevel-helical Gear Units
带辅传 With Auxiliary Drive
空载驱动 Maintenance Drive

三级 Three Stage
类型 Type TB3...
规格 Sizes 13...18

规格 Size	辅传减速机 Auxiliary gear motor	尺寸 mm 输入轴															Dimensions in mm Input shaft								
		i _N =25-45			i _N =25-50			i _N =25-56			i _N =50-71			i _N =56-71			i _N =63-71			G ₁	G ₃				
		d ₁ ¹⁾	l ₁	l ₃	d ₁ ¹⁾	l ₁	l ₃	d ₁ ¹⁾	l ₁	l ₃	d ₁ ¹⁾	l ₁	l ₃	d ₁ ¹⁾	l ₁	l ₃	d ₁ ¹⁾	l ₁	l ₃						
13	TKF88-Y4-44.02	80	165	130							60	140	105								1125	1160			
14	TKF88-Y4-44.02							80	165	130											60	140	105	1195	1230
15	TKF88-Y4-44.02	90	165	130							70	140	105											1367	1402
16	TKF88-Y4-44.02				90	165	130							70	140	105								1413	1448
17	TKF88-Y4-44.02	110	205	165							80	170	130											1560	1600
18	TKF88-Y4-44.02				110	205	165							80	170	130								1620	1660

规格 Size	尺寸 mm 减速机													Dimensions in mm Gear units				
	a	A ₁	A ₂	b	B ₁	c	d ₆	e ₃	E	G ₆	G ₈ ⁵⁾		h	H				
	13	1290	425	475	550	325	60	210	265	635	1180	453	433*	440	935			
14	1430	425	475	550	325	60	210	265	705	1250	453	433*	440	935				
15	1550	485	520	625	365	70	210	320	762	1420	500	476*	500	1035				
16	1640	485	520	625	365	70	210	320	808	1470	500	476*	500	1035				
17	1740	535	570	690	395	80	230	370	860	1620	532	508*	550	1145				
18	1860	535	570	690	395	80	230	370	920	1680	532	508*	550	1145				

规格 Size	尺寸 mm 减速机										Dimensions in mm Gear units				
	m ₁	m ₂	m ₃	n ₁	n ₂	s	L ₁ ⁵⁾	L ₃	L ₄	L ₅	L ₆	D ⁵⁾			
	13	545	545	475	100	305	35	805	790*	190	628	362	212	320	290*
14	545	685	475	100	375	35	805	790*	190	628	362	212	320	290*	
15	655	655	535	120	365	42	850	835*	200	628	443	212	400	290*	
16	655	745	535	120	410	42	850	835*	200	628	443	212	400	290*	
17	735	735	600	135	390	42	882	867*	225	628	520	212	400	290*	
18	735	855	600	135	450	42	882	867*	225	628	520	212	400	290*	

规格 Size	尺寸 mm 输出轴									Dimensions in mm Output shaft				润滑油 lubrication		重量 weight	
	TB3SH			TB3HH			TB3DH			TKF	TB3	TKF ³⁾	TB3/TKF ⁴⁾				
	d ₂ ¹⁾	G ₂	l ₂	D ₂	G ₄	D ₃	D ₄	G ₄	G ₂	(L)	(L)	(kg)	(kg)				
13	200	335	350	190	335	190	195	335	480	12.7	145	141	2547				
14	210	335	350	210	335	210	215	335	480	12.7	155	141	2917				
15	230	380	410	230	380	230	235	380	550	12.7	230	141	3902				
16	240	380	410	240	380	240	245	380	550	12.7	240	141	4127				
17	250	415	410	250	415	250	260	415	600	12.7	315	141	5168				
18	270	415	470	275	415	280	285	415	600	12.7	325	141	5673				

3) TKF减速机重量 (不含润滑油重量), 其余相关数据详见 TK03 页;

4) 主减速机与辅传减速机组合总重量 (不含润滑油重量);

5) 不带*列为采用国产逆止器、超越离合器时尺寸, 带*列为选用国外逆止器、超越离合器时尺寸。

3) Weight of gear motor TKF (oil weight not included), other detailed data refer to Page TK03;

4) Gross weight of combination of main gear unit and auxiliary gear motor (oil weight not included).

5) Without * is the dimension using domestic backstop and overrunning clutch and with * is the dimension using imported backstop and overrunning clutch.

斗式提升机用减速机 Bucket Elevator Drives

直交轴减速机 Bevel-helical Gear Units
 带辅传 With Auxiliary Drive
 载荷驱动 Operation under load
 三级 Three Stage
 类型 Type TB3...
 规格 Sizes 4 ... 12

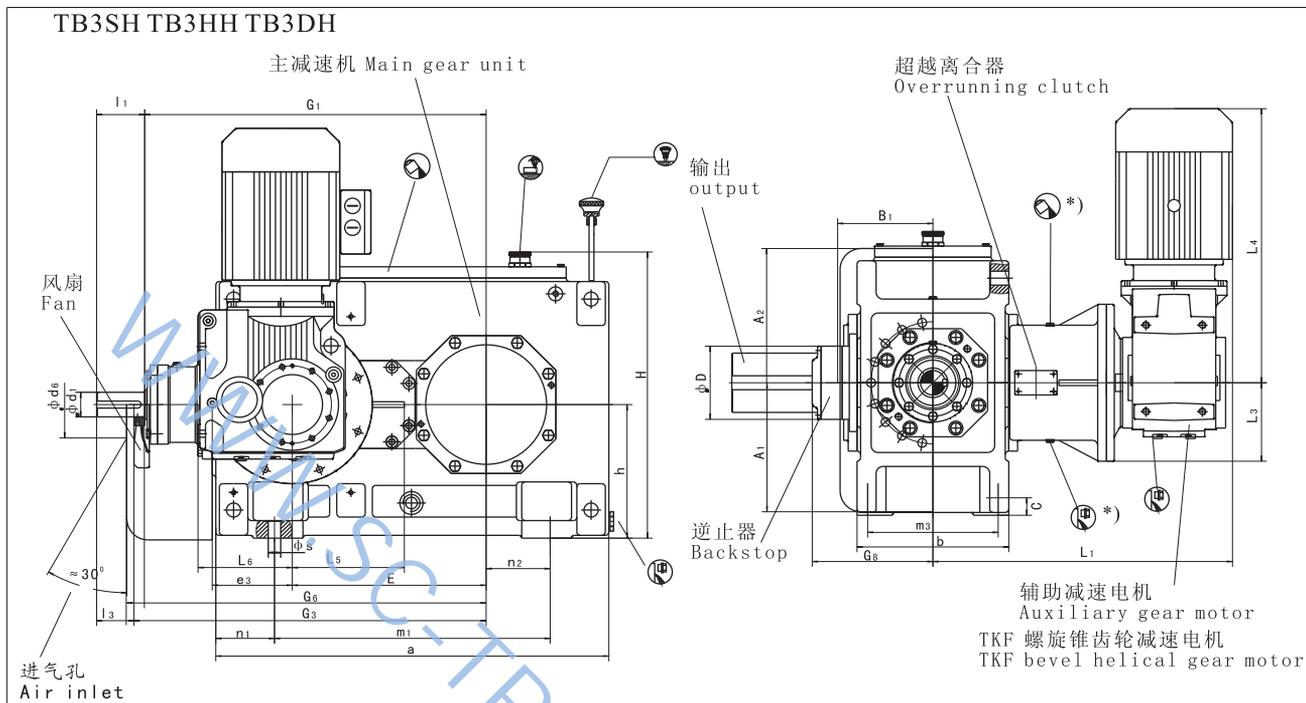

主减速机TB布置形式: D Design of main gear unit TB: D 齿轮减速机TKF输出轴方向: A Output shaft direction of gear motor TKF: A	主减速机TB布置形式: B Design of main gear unit TB: B 齿轮减速机TKF输出轴方向: B Output shaft direction of gear motor TKF: B
--	--

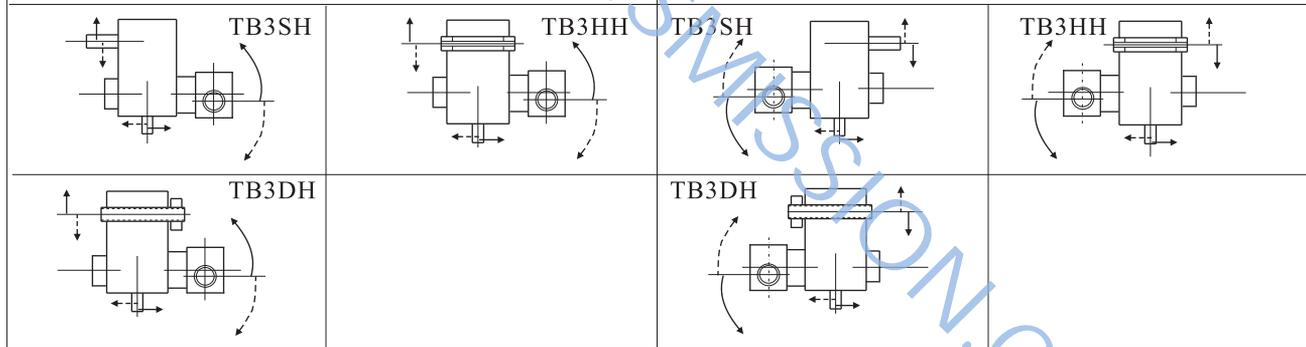

输出轴 Output Shaft

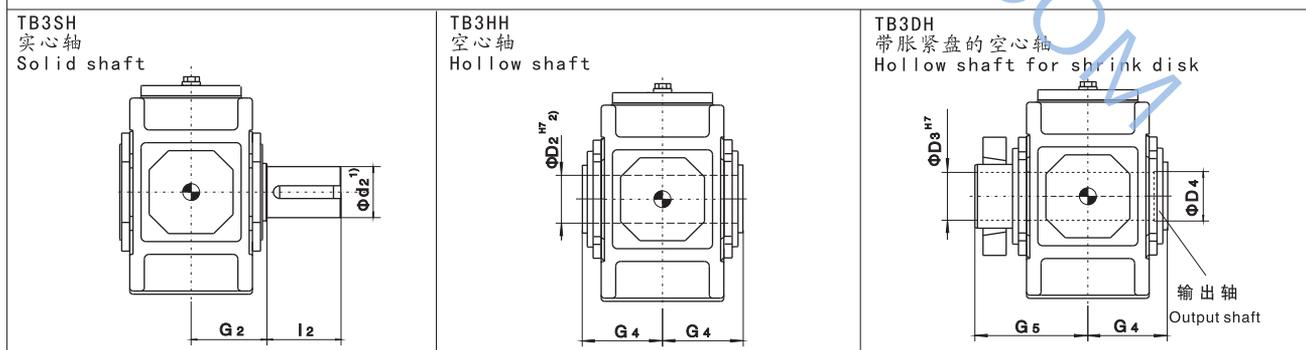

1) $k6 \leq \Phi 25$ $\Phi 28 \leq m6 \leq \Phi 100$ $n6 > \Phi 100$ 1) $k6 \leq \Phi 25$ $\Phi 28 \leq m6 \leq \Phi 100$ $n6 > \Phi 100$
 有关键和中心孔, 参见第 2 页 For parallel key and for center hole, see page 2
 2) 键槽GB/T1095-1979 2) Keyway GB/T1095-1979

*) 仅当采用国外超越离合器时加注润滑油, 若采用国产逆止器、超越离合器时则加注润滑脂。
 *) Fill lubrication only when selecting imported overrunning clutch, if domestic backstop and overrunning clutch are used please fill grease.

斗式提升机用减速机 Bucket Elevator Drives



直交轴减速机 Bevel-helical Gear Units
带辅传 With Auxiliary Drive
载荷驱动 Operation Under Load

三级Three Stage
类型Type TB3...
规格Sizes 4...12

规格 Size	辅传减速机 Auxiliary gear motor	尺寸 mm Input shaft											G ₁	G ₃	
		i _N =25-45			i _N =25-56			i _N =50-71			i _N =63-71				
		d ₁ ¹⁾	l ₁	l ₃	d ₁ ¹⁾	l ₁	l ₃	d ₁ ¹⁾	l ₁	l ₃	d ₁ ¹⁾	l ₁			l ₃
4	TKF58-Y1.1-35.7	30	70	50				25	60	40				500	520
5	TKF68-Y2.2-27.28	35	80	60				28	60	40				575	595
6	TKF68-Y2.2-27.28				35	80	60				28	60	40	610	630
7	TKF78-Y4-29.27	45	100	80				35	80	60				690	710
8	TKF78-Y4-29.27				45	100	80				35	80	60	735	755
9	TKF88-Y5.5-36.52	55	110	80				40	100	70				800	830
10	TKF88-Y5.5-36.52				55	110	80				40	100	70	850	880
11	TKF98-Y11-34.23	70	135	105				50	110	80				960	990
12	TKF98-Y11-34.23				70	135	105				50	110	80	1030	1060

规格 Size	尺寸 mm Gear units													h	H
	a	A ₁	A ₂	b	B ₁	c	d ₆	e ₃	E	G ₆	G ₈ ⁵⁾				
4	565	195	200	215	143	28	110	110	270	530	193	188*	200	445	
5	640	220	235	255	168	28	130	130	315	605	218	213*	230	512	
6	720	220	235	255	168	28	130	130	350	640	218	213*	230	512	
7	785	275	275	300	193	35	165	160	385	720	273	266*	280	602	
8	890	275	275	300	193	35	165	160	430	765	273	266*	280	617	
9	925	315	325	370	231	40	175	185	450	845	347	327*	320	697	
10	1025	315	325	380	231	40	175	185	500	895	347	327*	320	697	
11	1105	370	385	430	263	50	190	225	545	1010	397	342*	380	817	
12	1260	370	385	430	263	50	190	225	615	1080	397	342*	380	825	

规格 Size	尺寸 mm Gear units													D ⁵⁾
	m ₁	m ₃	n ₁	n ₂	s	L ₁ ⁵⁾	L ₃	L ₄	L ₅	L ₆				
4	355	180	105	85	19	479	474*	125	447	137	132	132	132*	
5	430	220	105	100	19	528	523*	125	536	165	140	160	150*	
6	510	220	105	145	19	528	523*	125	536	165	140	160	150*	
7	545	260	120	130	24	636	636*	150	693	210	180	195	190*	
8	650	260	120	190	24	636	636*	150	693	210	180	195	190*	
9	635	320	145	155	28	743	723*	175	674	255	212	230	210*	
10	735	320	145	205	28	743	723*	175	674	255	212	230	210*	
11	775	370	165	180	35	869	849*	225	806	315	265	280	210*	
12	930	370	165	265	35	869	849*	225	806	315	265	280	210*	

规格 Size	尺寸 mm Output shaft									润滑油 lubrication		重量 weight	
	TB3SH			TB3HH		TB3DH				TKF	TB3	TKF ³⁾	TB3/TKF ⁴⁾
	d ₂ ¹⁾	G ₂	l ₂	D ₂	G ₄	D ₃	D ₄	G ₄	G ₅	(L)	(L)	(kg)	(kg)
4	80	140	170	80	140	85	85	140	205	3.5	10	56	283
5	100	165	210	95	165	100	100	165	240	4	16	68	424
6	110	165	210	105	165	110	110	165	240	4	17	68	479
7	120	195	210	115	195	120	120	195	280	6.6	30	103	689
8	130	195	250	125	195	130	130	195	285	6.6	33	103	774
9	140	235	250	135	235	140	145	235	330	12.7	45	165	1105
10	160	235	300	150	235	150	155	235	350	12.7	48	165	1235
11	170	270	300	165	270	165	170	270	400	23.7	79	288	1821
12	180	270	300	180	270	180	185	270	405	23.7	84	288	2096

- 3) TKF减速机重量 (不含润滑油重量), 其余相关数据详见 TK03 页;
4) 主减速机与辅传减速机组合总重量 (不含润滑油重量);
5) 不带*列为采用国产逆止器、超越离合器时尺寸, 带*列为选用国外逆止器、超越离合器时尺寸。

- 3) Weight of gear motor TKF (oil weight not included), other detailed data refer to Page TK03 ;
4) Gross weight of combination of main gear unit and auxiliary gear motor (oil weight not included).
5) Without * is the dimension using domestic backstop and overrunning clutch and with * is the dimension using imported backstop and overrunning clutch.

斗式提升机用减速机 Bucket Elevator Drives

直交轴减速机 Bevel-helical Gear Units
带辅传 With Auxiliary Drive
载荷驱动 Operation under load

三级 Three Stage
类型 Type TB3...
规格 Sizes 13 ... 18

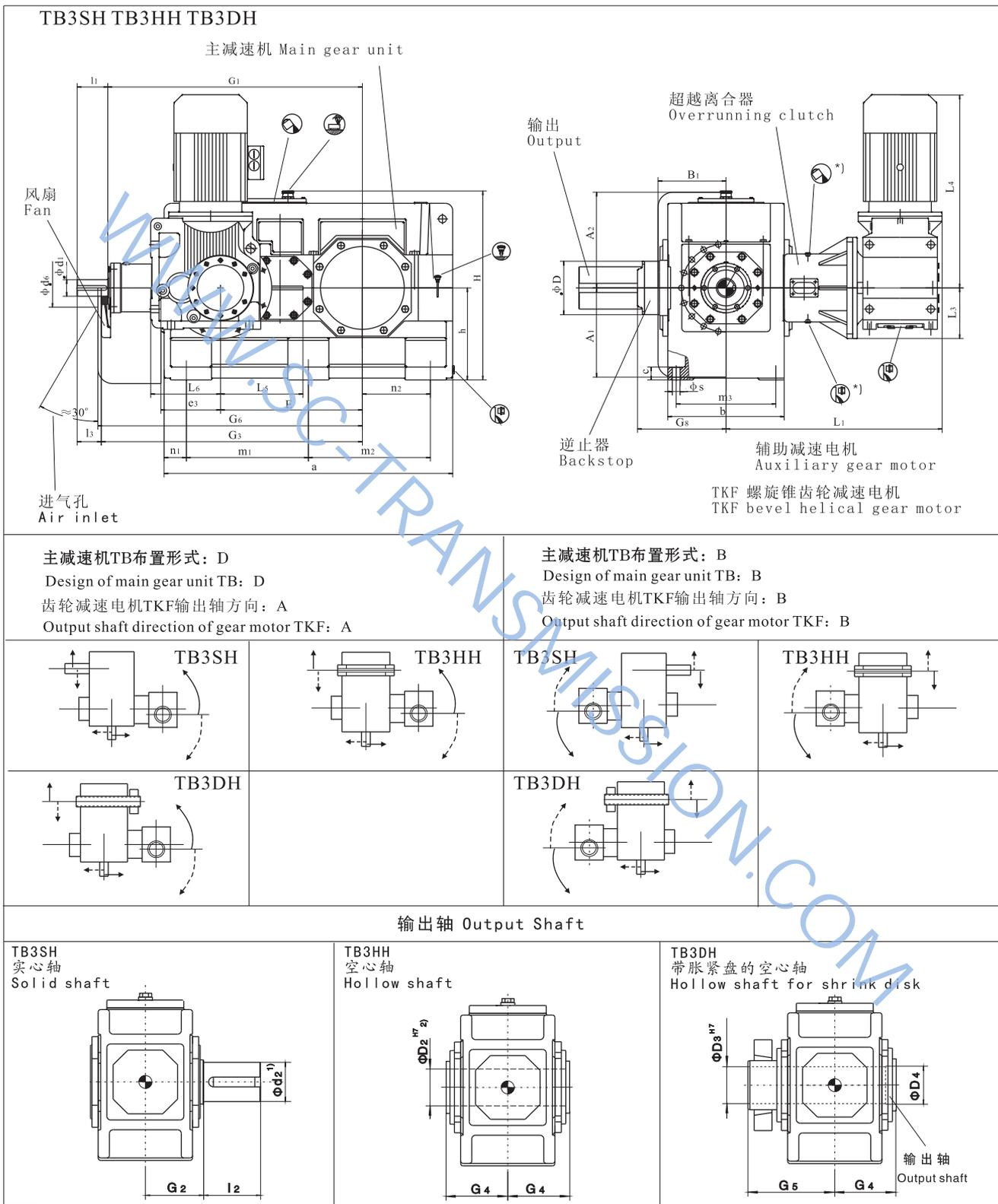

1) $k6 \leq \Phi 25$ $\Phi 28 \leq m6 \leq \Phi 100$ $n6 > \Phi 100$

有关平键和中心孔, 参见第 2 页

2) 键槽 GB/T1095-1979

1) $k6 \leq \Phi 25$ $\Phi 28 \leq m6 \leq \Phi 100$ $n6 > \Phi 100$

For parallel key and for center hole, see page 2

2) Keyway GB/T1095-1979

*) 仅当采用国外超越离合器时加注润滑油, 若采用国产逆止器、超越离合器时则加注润滑脂。

*) Fill lubrication only when selecting imported overrunning clutch, if domestic backstop and overrunning clutch are used please fill grease.

斗式提升机用减速机 Bucket Elevator Drives

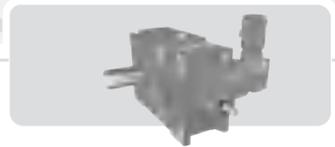

直交轴减速机 Bevel-helical Gear Units
带辅传 With Auxiliary Drive
载荷驱动 Operation Under Load

三级 Three Stage
类型 Type TB3...
规格 Sizes 13...18

规格 Size	辅传减速机 Auxiliary gear motor	尺寸 mm 输入轴 Dimensions in mm Input shaft																				
		i _N =25-45			i _N =25-50			i _N =25-56			i _N =50-71			i _N =56-71			i _N =63-71			G ₁	G ₃	
		d ₁ ¹⁾	l ₁	l ₃	d ₁ ¹⁾	l ₁	l ₃	d ₁ ¹⁾	l ₁	l ₃	d ₁ ¹⁾	l ₁	l ₃	d ₁ ¹⁾	l ₁	l ₃	d ₁ ¹⁾	l ₁	l ₃			
13	TKF108-Y18.5-28.59	80	165	130							60	140	105							1125	1160	
14	TKF108-Y18.5-28.59							80	165	130								60	140	105	1195	1230
15	TKF128-Y30-27.67	90	165	130							70	140	105								1367	1402
16	TKF128-Y30-27.67				90	165	130				70	140	105								1413	1448
17	TKF128-Y37-27.67	110	205	165							80	170	130								1560	1600
18	TKF128-Y37-27.67				110	205	165							80	170	130					1620	1660

规格 Size	尺寸 mm 减速机 Gear units													
	a	A ₁	A ₂	b	B ₁	c	d ₆	e ₃	E	G ₆	G ₈ ⁵⁾		h	H
13	1290	425	475	550	325	60	210	265	635	1180	453	433*	440	935
14	1430	425	475	550	325	60	210	265	705	1250	453	433*	440	935
15	1550	485	520	625	365	70	210	320	762	1420	500	476*	500	1035
16	1640	485	520	625	365	70	210	320	808	1470	500	476*	500	1035
17	1740	535	570	690	395	80	230	370	860	1620	532	508*	550	1145
18	1860	535	570	690	395	80	230	370	920	1680	532	508*	550	1145

规格 Size	尺寸 mm 减速机 Gear units													
	m ₁	m ₂	m ₃	n ₁	n ₂	s	L ₁ ⁵⁾	L ₃	L ₄	L ₅	L ₆	D ⁵⁾		
13	545	545	475	100	305	35	1024	986*	225	934	362	315	320	290*
14	545	685	475	100	375	35	1024	986*	225	934	362	315	320	290*
15	655	655	535	120	365	42	1181	1161*	275	1048	443	375	400	290*
16	655	745	535	120	410	42	1181	1161*	275	1048	443	375	400	290*
17	735	735	600	135	390	42	1223	1203*	275	1068	513	375	400	290*
18	735	855	600	135	450	42	1223	1203*	275	1068	513	375	400	290*

规格 Size	尺寸 mm 输出轴 Dimensions in mm Output shaft									润滑油 lubrication		重量 weight	
	TB3SH			TB3HH		TB3DH				TKF	TB3	TKF ³⁾	TB3/TKF ⁴⁾
	d ₁ ¹⁾	G ₂	l ₂	D ₂	G ₄	D ₃	D ₄	G ₄	G ₅	(L)	(L)	(kg)	(kg)
13	200	335	350	190	335	190	190	335	205	37	145	437	2547
14	210	335	350	210	335	210	215	335	240	37	155	437	2917
15	230	380	410	230	380	230	235	380	240	64	230	698	3902
16	240	380	410	240	380	240	245	380	280	64	240	698	4127
17	250	415	410	250	415	250	260	415	285	64	315	711	5168
18	270	415	470	275	415	280	285	415	350	64	325	711	5673

3) TKF减速机重量 (不含润滑油重量), 其余相关数据详见 TK03 页;

4) 主减速机与辅传减速机组合总重量 (不含润滑油重量);

5) 不带*列为采用国产逆止器、超越离合器时尺寸, 带*列为选用国外逆止器、超越离合器时尺寸。

3) Weight of gear motor TKF (oil weight not included), other detailed data refer to Page TK03 ;

4) Gross weight of combination of main gear unit and auxiliary gear motor (oil weight not included).

5) Without * is the dimension using domestic backstop and overrunning clutch and with * is the dimension using imported backstop and overrunning clutch.

斗式提升机用减速机 Bucket Elevator Drives

逆止器 Backstops

标准逆止器布置及输入输出转向关系
Standard backstop arrangement and dependence of direction of rotation

类型 Type	布置形式 Design 规格 Sizes 4 ... 18	
	B	D
TB3SH		
TB3HH		
TB3DH		

型号 Type					
规格 Sizes	E mm	G ₈ mm		D mm	
4	270	193	188*	132	132*
5	315	218	213*	150	160*
6	350	218	213*	150	160*
7	385	273	266*	190	195*
8	430	273	266*	190	195*
9	450	347	327*	210	230*
10	500	347	327*	210	230*
11	545	397	342*	210	280*
12	615	397	342*	210	280*
13	635	453	433*	290	320*
14	705	453	433*	290	320*
15	762	500	476*	290	400*
16	808	500	476*	290	400*
17	860	532	508*	290	400*
18	920	532	508*	290	400*

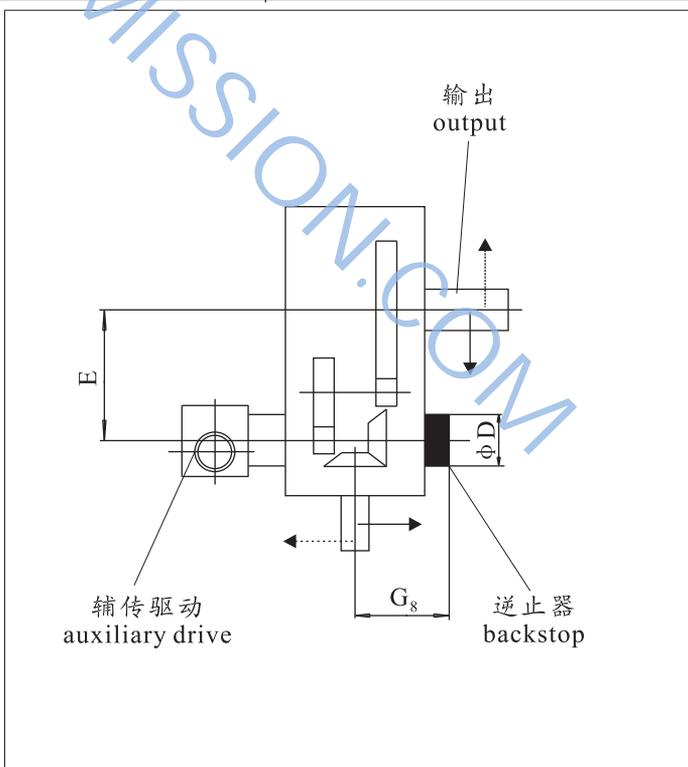

注：不带*列为采用国产逆止器、超越离合器时尺寸，带*列为选用国外逆止器、超越离合器时尺寸。

Note: Without * is the dimension using domestic backstop and overrunning clutch and with * is the dimension using imported backstop and overrunning clutch.